



**ARJES**

Recycling Innovation







***COMPAKTOR***  
***THE COMPACT CLASS***

# OUR SHREDDERS OF THE ARJES COMPACT CLASS



When choosing the right machine, our customers are usually faced with the question of which shredder is right for their specific requirements. Therefore, we have divided our unique two-shaft shredders into three product lines to help you make the right decision.

## Fields of application KOMPAKTOR class

-  Construction & demolition waste
-  Natural and waste wood
-  Commercial waste
-  Rubber and old tires
-  Paper and cardboard



## PRODUCT LINE **COMPAKTOR**

Upholding the motto "never change a running system", for the mobile compact class we are offering proven ARJES technology with a field-tested and competitive design. The product line COMPAKTOR has a new name, but when it comes to its structure, it is not a blank sheet on the global recycling market. Especially disposal companies of the construction and demolition sector value the ARJES brand for their extremely flexible and strong shredder that comes along with the best price-performance ratio of the industry. Also operators who want to expand their range of products for a mobile shredder, will find the best solution in this field.

The mobile shredder impresses with its combination of unique track system and hook lift as well as an intelligent SCU control system. The stationary electric version is divided into two separate units, which enables easy integration into existing recycling plants or use as a stand-alone machine. The quick change system for our shredding shafts is a standard feature of every ARJES machine.

Besides the reliable shredding of construction and demolition waste, the ARJES compact class provides a variety of applications for the processing of domestic and commercial waste, rootstocks, old timber, fresh wood, and many more.



\*Depends on the equipment of the shredder, the shaft configuration, the position of the side combs and the optimum material feed. The performance data given are average values without guarantee!

# COMPAKTOR 300 MOBILE COMPACT CLASS

## REVERSIBLE FAN

**Included!**  
Efficient engine cooling and cleaning for a significantly longer lifetime



## SHREDDING UNIT

Large-volume hopper with proven two-shaft system including **reinforced quick change cassette**



## SCU CONTROL SYSTEM

Including **remote control** and predefined shredding programs that adjust rotation and speed of shafts



## CRAWLER CHASSIS

**Included!** Guarantees optimum mobility on every surface; rubber tracked crawler systems optionally available



## WATER SPRINKLER

**Included!**  
Connection to reduce dust generation when the shredded material is discharged



## OVERBELT MAGNET

**Included!**  
Strong permanent magnet for effective Fe separation



## DRIVE

Powerful **VOLVO PENTA 5 litre diesel engine** for low fuel consumption and maximum efficiency

POWERED BY  
**VOLVO PENTA**

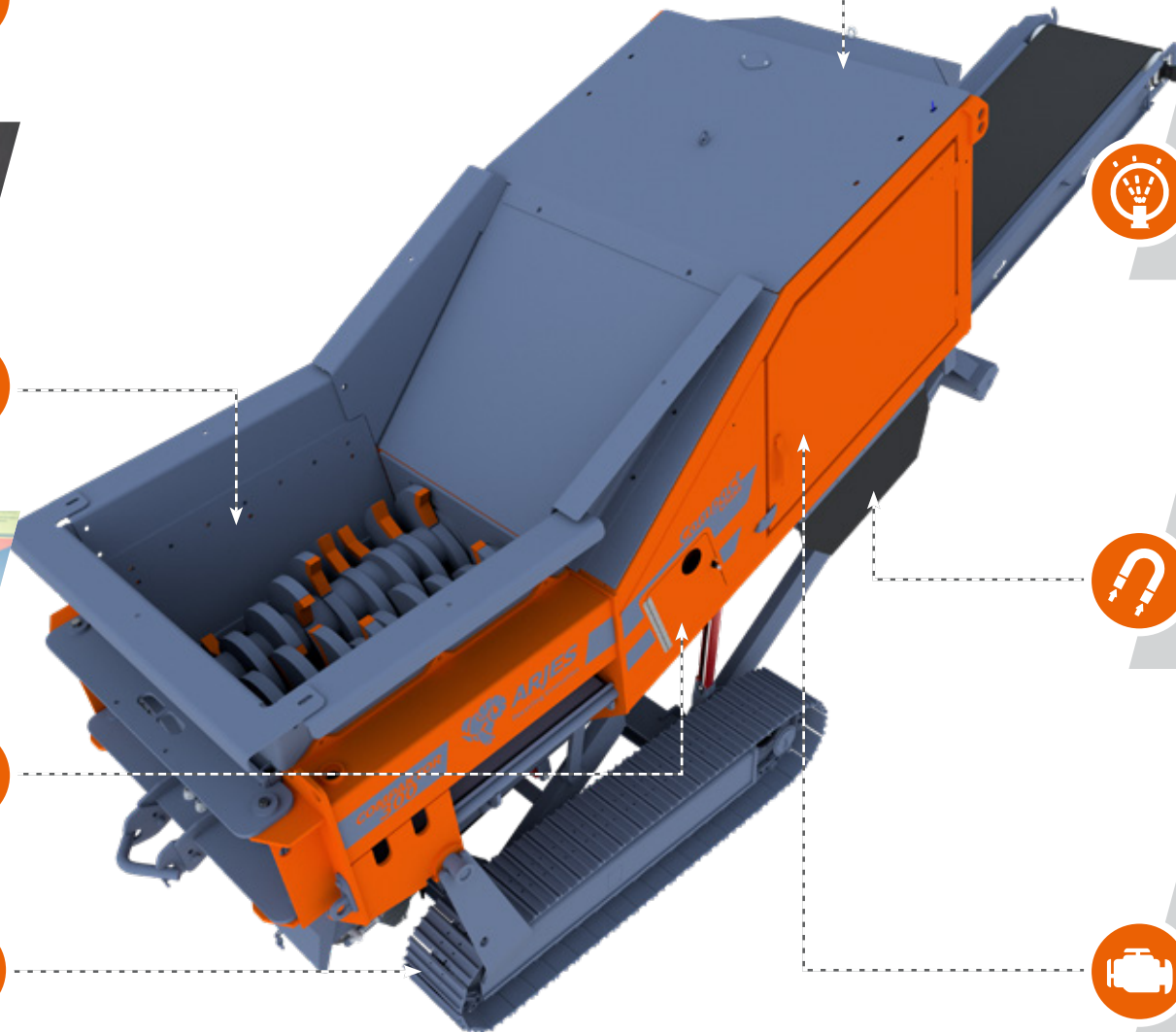

## TECHNICAL DATA

### DIMENSIONS

Version	Crawler track system and hook lift
Length (mm)	7,800 / 7,200 (transport)
Width (mm)	2,300 / 2,300 (transport)
Height (mm)	3,700 / 2,600 (transport)
Total weight (kg)	15,000

### DRIVE

#### EU / US

#### ROW\*\*

Engine (Volvo Penta)	TAD 582 VE	TAD 551 VE
Emission standard	EU Stage V / EPA Tier IV	Stage III A
Power (kW / HP)	160 / 220	
Fuel capacity (l)	330	
Gearbox	Bonfiglioli	

### DISCHARGE BELT

Discharge height (mm)	3,100
Width (mm)	800
Included	Overbelt magnet and water sprinkler system

### SHREDDING UNIT

Hopper volume (m <sup>3</sup> )	2.25
Shaft length (mm)	1,500
Shaft diameter (mm)	680
Weight (kg / cassette)	3,100
Rotation speed (rpm)	38

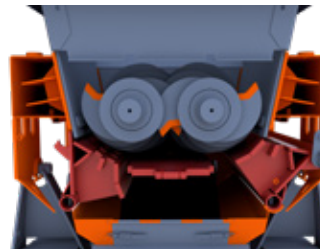

### Mechanically adjustable side combs

The side combs can be opened or closed, depending on material and customer requirements; decreasing the output size or increasing the throughput rate.

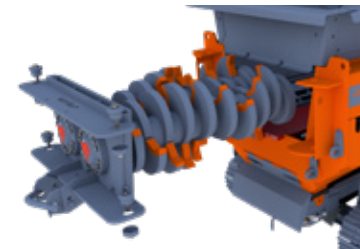

### Quick change system for tool shafts

Simplify maintenance, reprocessing and type change of your shredding shafts with an effortless mounting and dismantling of the pair of shafts in record time.



### Easy transport to any place of work

Due to the low empty weight and the hydraulically lowerable chassis, transport with hook lift attachment is possible without any problems.

\*Recommended retail price FCA plus applicable VAT and additional costs (transport, insurance, customs, etc.); \*\* Rest of the world (country-specific requirements)

# COMPAKTOR 300 e-pu STATIONARY COMPACT CLASS



## SHREDDING UNIT

Large-volume hopper and two-shaft system with **quick-change cassette**



## OVERBELT MAGNET

**Optional!** Height-adjustable permanent magnet for effective Fe separation



## STATIONARY

Used as an individual machine or optional integration in recycling plants according to customer requirements

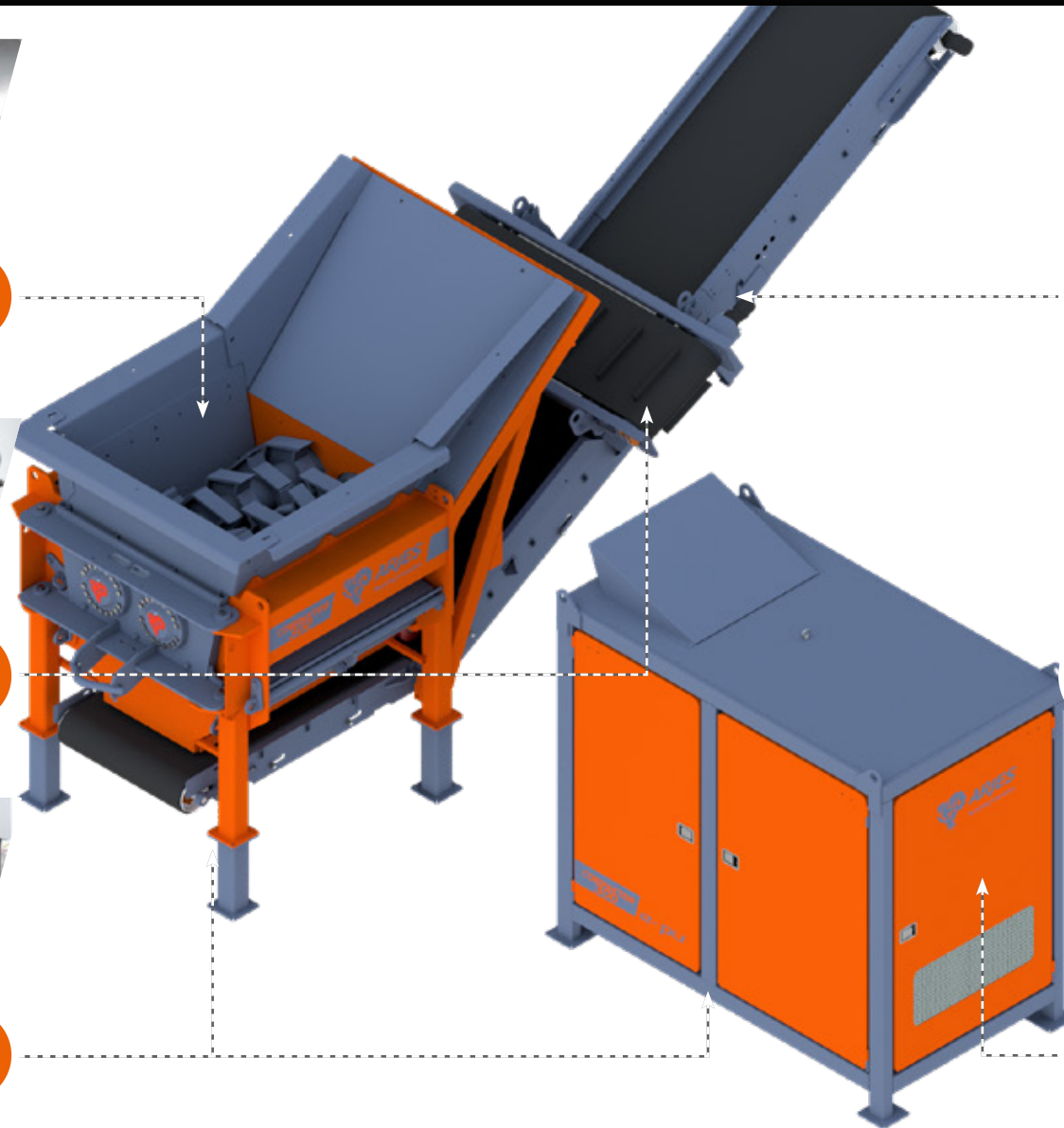

## DISCHARGE BELT

**Optional!** Conveyor belt for efficient material discharge according to customer requirements



## CONTROL SYSTEM

Operation via **remote control** and optional integration into complete systems possible according to customer requirements

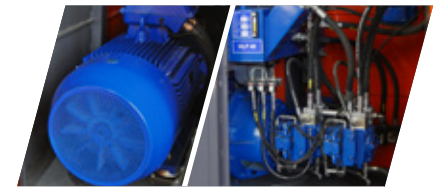

## DRIVE

Powerful **electric motor** performs with high efficiency and low energy costs



## TECHNICAL DATA

### DIMENSIONS

Version	Stationary
Shredding Unit	
Length (mm)	3,300 / 6,750 (incl. discharge belt)
Width (mm)	2,300
Height (mm)	3,200
Control Unit	
Length (mm)	2,700
Width (mm)	1,600
Height (mm)	2,700
Total weight (kg)	12,000 (shredding unit with discharge belt) 3,500 (power unit)

### DRIVE

Engine	Electric
Power (kW)	160
Gearbox	Bonfiglioli

### SHREDDING UNIT

Hopper volume (m <sup>3</sup> )	2.25
Shaft length (mm)	1,500
Shaft diameter (mm)	680
Weight (kg / cassette)	3,100
Rotation speed (rpm)	38



### Separate drive and control unit

Due to the separate installation of the shredding and control unit with a maximum distance of 6 meters to each other, vibrations on the control system are clearly minimized. Additionally, this effects a dust and dirt reduction.

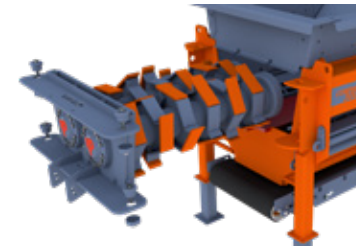

### Quick change system for tool shafts

Easy installation and dismantling of the tool shafts within a very short time makes it easy to maintain, refurbish and change the shafts with an almost uninterrupted operation.



### Mechanically adjustable side combs

To change the requested output grain size, the side-arranged combs can be opened or closed in full. Thus the performance of the shredder can be adjusted in accordance with the type of material and the customer's requirements.



**ARJES GmbH**

Borntalstraße 9  
D-36460 Krayenberggemeinde

✉ info@arjes.de

🌐 [www.arjes.de](http://www.arjes.de)

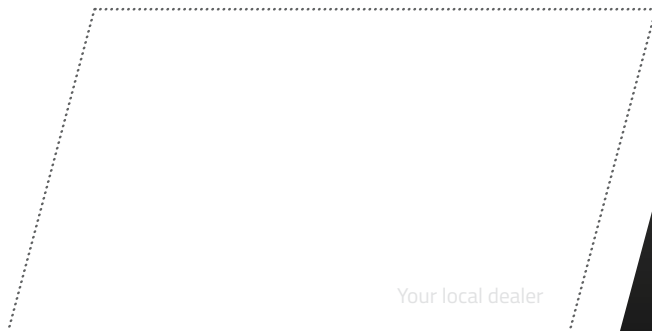

Your local dealer

Disclaimer: We reserve the right to make technical changes, misprints and errors. All specifications refer to the standard version without optional features. Status: June 2024



## 5 CONVINCING ARGUMENTS FOR OUR COMPACT CLASS

- 1 Best price-performance ratio in its class**  
Incl. standard attachments\* (e.g. reversible fan, magnet etc.)
- 2 Largest range of applications**  
Processing of different types of material with the toughest requirements (such as commercial waste, natural and waste wood, construction waste, etc.)
- 3 Revolutionary shaft quick change system**  
Shortens maintenance times, refurbishment and changing different shaft types for almost uninterrupted operation
- 4 Innovative SCU plug and play control**  
Predefined shredding programs that control rotation and speed of shafts for user-friendly operability
- 5 Maximum mobility in every situation**  
Standard crawler track system, transport/loading via hook lift\*

\*only available for mobile machines